



Steel radiators

Quality assessment RAL-GZ 618

August 2017



Published by

RAL Deutsches Institut für
Gütesicherung und Kennzeichnung e.V.
("German quality assessment and labelling institute")
Fränkische Straße 7
53229 Bonn Germany

Phone: +49 (0)228 6 88 95-0
Fax: +49 (0)228 95-430
E-Mail: RAL-Institut@RAL.de
Internet: www.RAL.de

No reprinting allowed of the document or of any extracts

RAL also reserves the right to translation into other languages.

© 2017, RAL, Bonn

Available from:

Beuth-Verlag GmbH
Burggrafenstr. 6 · 10787 Berlin (Germany)
Phone: +49 (0)30 26 01-0 · Fax: +49 (0)30 26 01-1260 · E-Mail: info@beuth.de
Internet: www.beuth.de · www.mybeuth.de

Steel radiators

Quality assessment RAL-GZ 618

**Gütegemeinschaft
Heizkörper aus Stahl e.V.
Frankfurter Strasse 720-726
51145 Cologne (Germany)
Tel. +49 (0) 2203 935 93-0
Fax +49 (0) 2203 935 93-22
Email: info@Heizkoerper-RAL.de
Internet: www.Heizkoerper-RAL.de**



These quality and inspection regulations have been prepared jointly by RAL Deutsches Institut für Gütesicherung und Kennzeichnung e.V., (the German quality assessment and labelling institute), under the principles for quality marks in acceptance proceedings with the collaboration of the Federal Ministry of the Economy and Technology and with the assistance of technical and commercial experts and the competent authorities. The quality and inspection regulations were revised in April 2007.

Bonn, January 2017

**RAL DEUTSCHES INSTITUT
FÜR GÜTESICHERUNG
UND KENNZEICHNUNG E.V.**

Quality and inspection regulations for steel radiators

1	Scope of validity	5
1.1	Field of application	5
1	Normative references	5
2	Quality and inspection regulations	5
2.1	Conformity to Standards	5
2.1.1	Procedure for substantiating conformity to Standards	5
2.1.2	Scope of tests to substantiate conformity to Standards	6
2.1.3	Types of tests for proof of conformity to Standards	6
2.2	Materials	7
2.3	Dimensions and limits.....	7
2.4	Processing	7
2.4.1	Base material	7
2.4.2	Joining process.....	8
2.4.3	Working pressures and pressure tests.....	8
2.5	Coating	8
2.5.1	Priming coat	8
2.5.2	Finishing coat.....	8
2.6	Manufacturers data	8
3	Monitoring.....	8
3.1	Initial inspection	8
3.1.1	Substantiation of conformity to Standards	8
3.1.2	Adherence to quality and inspection regulations.....	8
3.1.3	Substantiation of a reliable internal inspection system	9
3.2	Internal inspection.....	9
3.3	External Inspection.....	9
3.3.1	Substantiation of conformity to Standards	9
3.3.2	Testing of labelling	9
3.3.3	Adherence to these quality and test regulations.....	9
3.3.4	Substantiation of a reliable internal monitoring system	9
3.3.5	Monitoring changes.....	9
3.3.6	Rectification of defects.....	9
3.4	Test report.....	9
3.5	Testing costs	9
4	Changes to quality marked radiators	9
5	Labelling	9
6	Amendments	10
Appendix A:	Quality requirements for panel radiators	12
Appendix B:	Selection of models for testing from model series and families	30
Appendix C:	Confirmation that the appendix to the obligation note is up to date.....	36

Executive Regulations for the awarding and holding of the quality mark for steel radiators

1	Quality basis	37
2	Award	37
3	Use	37
4	Monitoring	37
5	Penalties for violations	38
6	Appeals	39
7	Re-awards	39
8	Changes	39
Sample 1:	Obligation note	40
Sample 2:	Award Certificate	42

Quality and inspection regulations for steel radiators

1 Scope of validity

1.1 Field of application

These quality regulations apply to steel radiators for use in heating systems the task of which consists of transferring the heat provided by the heating water by convection and radiation. This includes all radiators and convectors designed for installation in central heating systems in buildings and for operating with water or steam at temperatures below 120°C and are supplied from a separate heat source.

Coatings for radiators intended for rooms with a corrosive and/or damp atmosphere are not a subject of the quality and inspection regulations. Such rooms also include bathrooms and toilets in which moisture frequently forms due to projection, e.g. in public or sports facilities. Kitchens in addition to areas outside the projection range of showers and toilets or similar installations in bathrooms of living areas etc. are not to be regarded as rooms with a corrosive and/or damp atmosphere in this case.

These quality and inspection regulations define quality requirements for the steel radiator as a product and for its monitoring.

These quality and inspection regulations also define the requirements for the quality assurance system of the user of the quality mark so that substantiation can be provided that the products have been manufactured and supplied in accordance with these guidelines.

1 Normative references

These quality and inspection regulations refer to and thus contain regulations under various Industrial Standards. The references are quoted at the relevant points and the publications are listed at the end. The most recently revised version applies in each case.

DIN EN 442-1	Radiators and convectors – Part 1: Technical specifications and requirements
DIN EN 442-2	Radiators and convectors – Part 2: Test methods and rating
DIN EN 10131	Cold-rolled uncoated low carbon and high-yield strength steel flats for cold forming; tolerances on size and geometrical tolerances
DIN EN 10204	Metallic products – Types of inspection documents
DIN EN ISO 2409	Paints and varnishes – Cross-cut test
EN ISO 9001	Quality management systems – Requirements
ISO 2768-1	General tolerances; tolerances for linear and angular dimensions without individual tolerance indications

DIN 55900-1 Coatings for radiators – Part 1: Terms, requirements and tests for primers and industrially applied priming coats.

DIN 55900-2 Coatings for radiators – Part 2: Terms, requirements and tests for finishing paints and industrially applied finishing coats.

2 Quality and inspection regulations

The basis for awarding the quality mark is proof of marketability (CE marking) of the steel radiators based on EN 442-1 and EN 442-2. Details of this conformity procedure are described by the Quality Association for Steel Radiators in section 2.1 et seq. Associated with this is also proof of compliance with the accompanying standards according to section 1.2 in the sections which refer to the scope of validity of these quality and inspection regulations.

Furthermore, the quality requirements defined by the quality association for steel radiators according to appendices A and B which go over and beyond the pertinent standards must comply with by the applicant/licensee.

2.1 Conformity to Standards

One indispensable requirement for granting the quality mark is proof that the radiator conforms to Standards EN 442-1 and EN 442-2.

2.1.1 Procedure for substantiating conformity to Standards

2.1.1.1 Test laboratories

The test described below have to be carried out on a "reference test bench" (EN 442-2 sub-section 5.2.2) or on a "recognised test bench" (EN 442-2 sub-section 5.2.4.2.2). The test benches have to be accepted by the Executive Committee of RAL-Gütegemeinschaft Heizkörper aus Stahl (hereinafter called "the Association" for short).

2.1.1.2 Test request and sampling

The applicant will request the first test for conformity to the Standards without any set formalities from a test laboratory in accordance with sub-section 2.1.1.1 above.

The customer will deliver the number of radiators necessary according to EN 442-2 sub-section 4.2 and/or agreed between him and the test laboratory together with the test request. The customer will make no charge for delivering the radiators or for collecting them afterwards.

The manufacturer will select and deliver the first samples for testing for conformity to the Standards.

Quality and Test Specifications

Samples for all later tests under the provisions of sub-section 2.1.3 will be taken from on-going production or from the manufacturer's warehouse by the inspector entrusted with monitoring under the provisions of Section 3 and accepted by the Association. The radiators selected for this purpose are to be provided with permanent labelling. The holder of the mark will arrange for transportation of the radiator to the test laboratory after discussion and agreement with the laboratory.

2.1.1.3 Submission of proof of conformity

The complete copy of all reports (see sub-section 2.1.3) necessary for validly substantiating conformity to the Standards have to be available to the Association.

2.1.2 Scope of tests to substantiate conformity to Standards

The selection of to be tested radiators will be made according to EN 442-2 sub-section 4.2.

2.1.2.1 Model testing

Model testing is the inspection of a radiator with a certain height, length, and depth as defined in EN 442-2.

2.1.2.2 Model series testing

All radiators of a given design in which the geometric differences between the individual models in one characteristic dimension give rise to the expectation of a permanent change in their heat output can be allocated to a model series according to EN 442-2.

Changes in a second characteristic dimension require allocation to a new model series

A model "triangle" is deemed to exist as a special form of a model series if, for instance, different heights of the convector panel are linked to the structural height of the radiator as a characteristic dimension.

The model series testing consists of model testing on models selected in accordance with EN 442-2 sub-section 4.2 and the calculation of the heat output of all models in the model series on the basis of the relevant regression calculation. In the case of model "triangles" sub-section 4.2 of EN 442-2 is applied both to the structural height of the radiator and of the convector. Appendix B1 shows the selection of samples for testing for this case, taking three typical "triangles" as examples.

2.1.2. Model family testing

A model family testing is an inspection of more than two model series that belong to a model family.

A model family in the broader sense exists if all the models in the relevant model series are made up of uniform basic elements such as the panels that carry the water and the convector panels but no permanent relationship is to be expected between the structural depth and the heat output (see Appendix B 2.1).

A model family in the narrower sense exists if more than one characteristic (primary or secondary) dimension gives rise to the expectation of a permanent dependency of the heat output (see Appendix B 3.1).

Appendices B 2.2 and B 3.2 show the selection of the models to be tested on the basis of typical examples.

2.1.2.4 Special criteria for the selection of the models for testing

According to EN 442-2, a supplementary test can be carried out on models having minor technical modifications. A minimum of one model of a model series or model family having the minor technical modification shall be subjected to the supplementary test by measurement. If the deviations for supplementary tests required by the standard are not met they shall be considered to be separate model series or model families.

Minor technical modifications include:

- Model with/ without casing
- Model with/ without integrated valve set

If the construction of the radiator in practice, or the way it is presented in the manufacturer's documentation, gives rise to the expectation that some form of connection has been included other than one that complies with EN 442-2 sub-section 5.3.1, the performance test has to be carried out with this kind of connection.

In addition to this the test laboratory will also define the number of models that may have to be tested additionally in order to enable a definitive statement to be made about the heat output of all the models.

2.1.3 Types of tests for proof of conformity to Standards

2.1.3.1 Initial test for proof of conformity to Standards

An initial test is an essential requirement for issuing valid substantiation of conformity to Standards.

The substantiation that the radiator has passed the initial test for conformity to Standards is a complete test report. The test report must be issued according to the forms laid down in EN 442-2 Appendix E. It also has to contain a confirmed dimensional sketch of the radiator in DIN A4 format, with all the data relevant to heat output. Various examples are listed in EN 442-2 Appendix G.

2.1.3. Secondary test

A secondary test has to be carried out within 12 months of the initial test, or at the least the customer has to be able to show that he has requested one within this period of time.

The secondary test consists of model testing and testing of the labelling.

It covers one radiator from each model series, or 3 in the case of model "triangles". In the case of model families with n model series, radiators from $n/2$ model series (rounded) have to be submitted to secondary test.

If standard heat output figures emerge from the secondary test that deviate by more than 4% from the catalogue output according to EN 442-2, or if dimensions are measured that exceed the maximum deviations laid down in EN 442-2 sub-section 4.3.3, Table 3, Section 5 of the Executive Regulations will take effect.

The substantiation that the radiator has passed the secondary test is a complete test report in compliance with

sub-section 2.1.3.1. If the dimensional sketch of the radiator has not been altered from the last time conformity to Standards was substantiated, a note to this effect on the test report will be sufficient.

2.1.3.3 Follow-up test for conformity with Standards

Radiators that have been tested have to be submitted to a follow-up test in order to confirm that they conform to the radiators that were submitted to the initial conformity test.

The follow-up test is carried out within a period of 5 years after the initial conformity test.

The nature and scope of these tests corresponds to the secondary test described in sub-section 2.1.3.2, with the necessary tests being distributed evenly over this five-year period.

The same regulations apply to the proof that the radiators have passed the follow-up test as to the secondary test.

2.1.3.4 Check test

If there is any doubt about whether a radiator that bears the mark of quality actually does conform to the Standards, a check test can be requested.

The check test basically has to be carried out as a model inspection on 2 equal models as described in sub-section 2.1.2.1.

The request for the check test basically has to be placed with the test laboratory that carried out the initial test of the radiator in question.

The client for the check test is the Association but the costs of this procedure have to be born by the applicant (complainant). These costs include the test laboratory's fee, the cost for selecting and transporting the relevant radiator to the test laboratory, and the cost of the radiator itself.

If the check test reveals deviations that fall short of the readings obtained from the initial inspection by more than 4%, or if dimensions are discovered that exceed the limit deviations set by EN 442-2 sub-section 4.3.3 Table 3, the Association will inform the mark-holder accordingly. He then has the right to examine the matter. Otherwise Section 5 of the Executive Regulations will apply.

The substantiation that the radiator has passed the check test is a complete test report in compliance with sub-section 2.1.3.1. If the dimensional sketch of the radiator has not been altered from the last time conformity to Standards was substantiated, a note to this effect on the test report will be sufficient.

2.1.3.5 Supplementary test

A supplementary test is a test for the purpose of establishing the effect of minor technical changes on the heat output of radiators that have already been tested for quality.

The test laboratory investigates the effect of the change on heat output by means of a visual check and, at its own free discretion, carrying out one or more model testings.

If the supplementary test reveals a deviation of up to plus or minus 4% of the measured standard heat output, it will be permissible for the old values for the model series to be used.

If the supplementary test reveals any greater deviation than $\pm 4\%$, any negative deviation of up to -6% will be treated as substantiating the percentage converted values. If there is a positive deviation of up to $+6\%$, the conversion can be deleted upon the applicant's request so that the lower values will be regarded as having been substantiated.

If the deviation is greater than 6% a fresh test will have to be carried out in accordance with sub-section 2.1.2.2 or 2.1.2.3 as an initial test to substantiate conformity with the Standards.

The findings of the supplementary test have to be shown as follows:

- in the case of an assessment based on a visual check: by a written confirmation;
- if readings have been taken: by a complete report in accordance with sub-section 2.1.3.1 on the tests with the scope defined above;
- This report will contain, for the whole related model series / family;
- the previous heat output figures or the ones that now have to be used;
- if a new initial test has to be carried out, a complete inspection report in accordance with sub-section 2.1.3.1,
- if the dimensional sketch of the radiator is unchanged from the previous substantiation of conformity, a note to this effect on the test report will be sufficient.

2.2 Materials

The quality of the material (for minimum requirements see EN 442-1 sub-section 4.1 and 4.2) has to be demonstrated with the relevant tests in the manufacturer's own laboratory or by a works certificate in compliance with EN 10204.

2.3 Dimensions and limits

The dimensions laid down in the construction drawings must be adhered to and must lie within the stated limits. In addition to the limits stated in EN 442-2, sub-section 4.3.3, Table 3, those for certain radiator models shown in Appendix A to these quality and inspection regulations must not be exceeded either.

The limits can be further tightened by data in the construction drawings.

The limits on the thickness of parts that do not carry water such as the convection plates must not exceed the "standard limits" according to EN 10131.

If no tolerances are shown for other dimensions, the "coarse" tolerance group (identification 'c') defined in ISO 2768-1 will apply.

2.4 Processing

2.4.1 Base material

Base materials have to be stored and processed in such a way that there can be no deleterious effect on the surface through mechanical damage or corrosion.

Quality and Test Specifications

The base material is to be labelled in such a way that there can be no confusion and the quality of the material can be demonstrated at any time.

2.4.2 Joining process

The production process that is used, and in particular the welding and other joining processes, must be tested and shown to be reliable for the process, and must also comply with the latest state of the technical art.

All design characteristics laid down for the joining techniques such as the lengths of the welding seams, the number of welding spots, and the distance between them have to be defined in the manufacturing drawings, and the production process has to adhere to them.

The construction and function of the joining machinery including any jigs and tools and the adjustment of the settings must be decided on the basis of the results of trials and destructive tests on samples and should also be documented.

2.4.3 Working pressures and pressure tests

Each radiator must undergo a pressure leakage test according to EN 442-1 sub-section 5.4

In addition to the tests for pressure resistance required by EN 442-1 sub-section 5.6, the radiators have to be subjected to a burst test. The conditions and minimum values are laid down in Appendix A for the individual types.

2.5 Coating

The pre-treatment and painting methods shall be tested according to EN 442-2 Appendix K at least once per year.

For coatings not covered by DIN 55900 parts 1 and 2 comparable methods shall be used.

2.5.1 Priming coat

Each radiator has to be provided with a priming coat in compliance with DIN 55900-1, "Coatings for radiators", on all the surfaces that are exposed to the air.

Substantiation for adequate protection from the coating is provided if the necessary tests have been carried out successfully in compliance with DIN 55900-1 and recorded in a test report. The tests have to be carried out once.

The materials and processes stated in the test report in compliance with DIN 55900-1 for the selection of samples must also be adhered to accordingly in the production of the radiators.

If changes are made in the pre-treatment, the processing, or the coating material, the quality of the coating must be substantiated by means of a fresh test.

2.5.2 Finishing coat

If radiators are sold ready painted, they have to be provided with a finishing coat in compliance with DIN 55900-2.

Substantiation for adequate protection from the coating is provided if the necessary tests have been carried out suc-

cessfully in compliance with DIN 55900-2 and recorded in a test report. The tests have to be carried out once.

The materials and processes stated in the test report in compliance with DIN 55900-2 for the selection of samples must also be adhered to accordingly in the production of the radiators.

If changes are made in the pre-treatment, the processing, or the coating material, the quality of the coating must be substantiated by means of a fresh test.

Care must be taken to ensure that the coating provides adequate protection from mechanical damage during correct and proper transportation and storage until the radiator is installed.

2.6 Manufacturers data

The data stated in the inspection reports will have a binding effect on all manufacturers' data.

Heat outputs stated by the manufacturer that are not in line with the standard conditions must be converted by using the equation of the characteristic curve taken from the relevant test report.

3 Monitoring

Adherence to the quality regulations for radiators by the user of the quality mark is checked by monitoring. This includes the requirements for the CE Marking according to EN 442-1. This consists of the initial inspection, internal and external inspection of each factory where radiators are produced which are labelled with the quality mark.

When the initial inspection has been carried out (3.1) external inspection (3.3) has to be requested from inspectors accepted by the Association.

3.1 Initial inspection

The initial inspection is an essential requirement for approval to bear the RAL quality mark. It includes the following elements:

- substantiation of conformity to the Standards,
- adherence to the quality and testing regulations,
- substantiation of a reliable inspection system.

If the initial inspection cannot be successfully completed, a repetition of the initial inspection will be necessary within the next six months to see whether the points giving rise to complaint have been eliminated. If this six-month period has expired, a fresh initial inspection will have to be carried out.

3.1.1 Substantiation of conformity to Standards

The inspection is made to see whether all the documentation is available for which provision is made in the procedure for substantiation of conformity to Standards (2.1.1).

3.1.2 Adherence to quality and inspection regulations

An adequate number of samples is taken to ensure adherence to these quality and inspection regulations and the

fulfilment of the requirements for the product under these quality and inspection regulations and the relevant appendices.

The radiators to be used for this purpose are selected by the examiner from current production or from the works warehouse.

The data in the Appendix on the obligation note have to be checked by the examiner for conformity to the Standards and for the correct application in the brochures and confirmed in the test report.

3.1.3 Substantiation of a reliable internal inspection system

The applicant must substantiate that the requirements are being met for a reliable quality management system.

3.2 Internal inspection

The user of the quality mark has to constantly monitor all the requirements of the quality and inspection regulations and their appendices.

For this purpose it is necessary to create, document, and maintain a quality management system that at least complies with EN ISO 9001 or equivalent and is able to produce objective substantiation that materials and manufacture, regardless of whether they are produced by the user of the mark himself or bought in from suppliers, meet the specified requirements.

The documentation from the internal inspection system has to be stored for at least 5 years and submitted to the inspection organisation.

3.3 External Inspection

In order to guarantee a uniform level of quality, and to ensure that voluntary marked radiators bear the mark of quality continue to conform to the one inspected in the initial inspection, inspection has to be carried out once a year by an external organisation.

3.3.1 Substantiation of conformity to Standards

An inspection is made to ensure that all documentation is available that is envisaged in the procedure for substantiating conformity to Standards (2.1.1).

3.3.2 Testing of labelling

The labelling is tested to ensure that it is complete and is correctly and properly attached.

3.3.3 Adherence to these quality and test regulations

An adequate number of samples is taken to ensure adherence to these quality and test regulations and the fulfilment of the requirements for the product under these quality and test regulations and the relevant appendices.

The radiators to be used for this purpose are selected by the examiner from current production or from the works warehouse.

3.3.4 Substantiation of a reliable internal monitoring system

The quality mark user must substantiate that the requirements are being met for a reliable quality management system in accordance with sub-section 3.2.

3.3.5 Monitoring changes

It is necessary to establish whether radiators have been modified since the last test, and whether the Association was informed of the changes in good time. For this purpose the user of the quality mark has to hand over a "Confirmation that the appendix to the note of obligation is up to date" (Appendix C) and to establish whether any test report has been received from a test laboratory in compliance with EN 442-2 on the performance of the necessary supplementary test.

3.3.6 Rectification of defects

Any defects identified by the inspection organisation are to be rectified immediately. If this is not possible a period for compliance of no more than 3 months has to be set.

The Association or an authorized institution will decide whether it is necessary for the inspection organisation to repeat its test when the defects have been rectified or whether a written assurance from the tested company that the defect has been rectified will be sufficient if a check is made at the next inspection.

3.4 Test report

The findings of the tests described in sub-sections 3.1 and 3.3 are recorded in a test report. The applicant/licensee and the Association are each sent a copy of the test report.

3.5 Testing costs

The costs of the initial inspection are borne by the applicant. The costs of the inspection and any check test for conformity to Standards will be borne by the user of the quality mark.

4 Changes to quality marked radiators

If a licensee makes changes to his inspection system, his production process, or any product with the quality mark, he has to inform the Association without delay.

If any changes are made to radiators with quality marks a supplementary test has to be carried out in accordance with sub-section 2.1.3.5 and the findings sent to the Association.

The Association will decide whether any additional external monitoring is necessitated by these changes.

5 Labelling

Steel radiators that can be demonstrated to comply with these quality and inspection regulations can be labelled with the symbol illustrated below as soon as the Associ-

Quality and Test Specifications

ation has awarded the manufacturer the quality mark for those radiators.



In addition, the manufacturer also has to provide the following information:

- manufacturer's name or identification,
- identification of the place of manufacture (code),
- registration number (type / version),
- maximum working pressure.

All marks must be easily legible and permanently affixed. Labelling with an adhesive label will be regarded as permanent for this purpose. The labelling must be attached to the radiator. In the case of radiators constructed in sections the labelling of individual sections or blocks of up to three sections can be omitted.

All documents shall clearly show which radiators bear RAL quality marks by stating the RAL Registration number.

The Executive Regulations for the awarding and holding of the quality mark for steel radiators will apply exclusively to the application of the quality mark.

6 Amendments

No amendments to the quality and inspection regulations shall have any validity unless RAL has given its prior written approval and shall not come into effect until an appropriate length of time has passed after the Board of the Association has announced them to the users of the quality mark.

Appendices to the quality and inspection regulations

Appendix A

Special requirements for specific radiator models

- A 1 Quality requirements for panel radiators
- A 2 Quality requirements for tubular steel sectional radiators
- A 3 Quality requirements for heated walls and convectors
- A 4 Quality requirements for bathroom and designer radiators made of pipe elements
- A 5 Quality requirements for sectional steel radiators
- A 6 Quality requirements for ribbed tubular convectors

Appendix B

Selection of the models to be inspected in model series and families

- B 1 Model "triangle": selection of models for inspection
- B 2 Model family in the broader sense
 - B 2.1 Typical example
 - B 2.2 Selection of models for inspection
- B 3 Model family in the narrower sense
 - B 3.1 Typical example
 - B 3.2 Selection of models for inspection

Appendix C

Confirmation that the appendix to the obligation note is up to date

Appendix A 1: Quality requirements for panel radiators

re 2.3 Dimensions and limits All data in mm

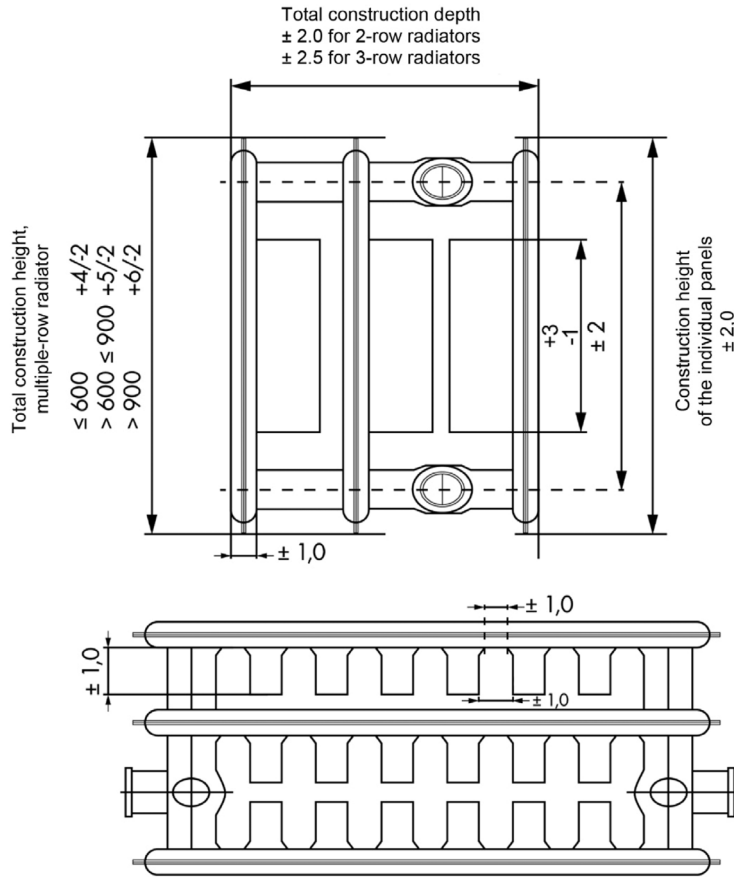

Construction length of the individual panels	≤ 800 ± 2
Construction length of the individual panels	> 800 ± 0.25%
Maximum structural length off-set over entire length	3
All radiuses at the curvatures of the convector sheets	+ 1.0 - 2.0

Curvature

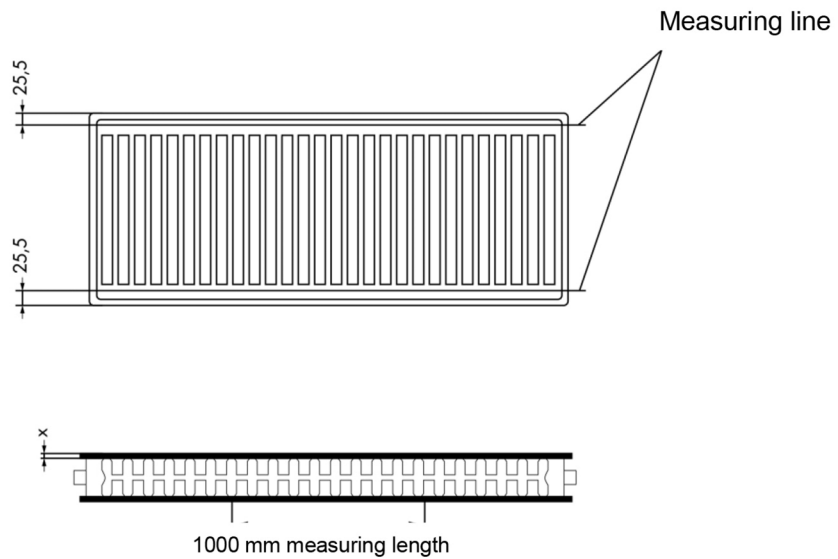

The permitted curvature x for panel radiators must not exceed $x \leq 4$ mm per 1000 mm length. Measurement of the curvature x for model 10 and 11 panel radiators (refer to appendix B 2.1 and B 3.1) is to be performed in the horizontal position on the top or bottom water duct of the radiator during the manufacturing process, e.g. before the lacquering process or any further handling. Measurement of the curvature x for other panel radiator models (refer to appendix B 2.1 and B 3.1) is to be performed during the manufacturing process, e.g. before the lacquering process, on the top or bottom water duct of a vertical radiator.

Incorrect positioning of the panel radiators results in a risk of the measured tolerance for curvature x ($x \leq 4$ mm per 1000 mm length) measured during the manufacturing process may be exceeded. Consequently, the manufacturer must ensure correct positioning of the panel radiators during operation.

As part of inspection, observance of the curvature x and correct positioning at the manufacturer's is controlled. The interval for the manufacturing control of curvature is to be performed analogously to the manufacturing control of the dimensions of the semi-finished and finished products.

re 2.4.3 Working pressures and pressure tests

The working pressure of the radiator is at least 6 bar. In case of intermediate values for the pressure levels indicated, the requirements of the respective higher operating pressure are to be observed.

Supplementing the test for pressure resistance required by EN 442-1 sub-section 5.6, the manufacturer has to carry out burst tests. The guideline values for this, with the related warning and intervention limits corresponding to the relevant working pressure are shown in the following table.

Working pressure in bar	6	8	10
Test pressure	7,8	10,4	13
Guideline figure	12	16	20
Warning limit	11	15	19
Intervention limit	10	14	17

All data are pressures above atmospheric pressure in bar

If the guideline figure is exceeded by 15% the burst test can be terminated.

The number of burst tests required is set in stages:

- Stage 1 1 test after 10 radiators on each production line
1 test after 100 radiators on each production line
- Stage 2 1 test per shift on each production line,
- Stage 3 1 test per day on each production line.

Procedure for application

Stage 1 is to use when:

- new production lines are being started up,
- major changes have been made in production lines,
- new welding parameters are being calculated,
- production is being changed over to a higher pressure level,
- when readings fall short of the intervention limit.

This does not include:

- changes in construction height or length,
- model changes,
- coil changes,
- insignificant changes in welding equipment,
- electrode changes.

If the readings do not fall short of the guideline figure after Stage 1, tests can be carried out in accordance with Stage 2. If the readings do not fall short of the guideline figure after 10 consecutive tests in Stage 2, Stage 3 can be applied.

If the readings in any test fall short of the guideline figure but not of the warning limit, that Stage should be retained; only when once again 10 consecutive tests have been carried out without falling short of the guideline figure can tests be carried out at the next higher Stage.

If the readings in any test fall short of the warning limit, tests must then immediately be conducted according to the next lower Stage. When 10 consecutive tests have been conducted in which the readings did not fall short of the guideline figure, the subsequent tests can be carried out according to the next higher Stage.

If the readings fall short of the intervention limit, tests will be carried out according to the necessary measures under Stage 1 with the subsequent test procedure.

Action to be taken if readings fall short of the guideline figure

Corrective action is necessary if the readings fall short of the guideline figure and the warning limit. They are to be laid down and documented in the Procedural Instructions under the quality assurance system.

If the readings fall short of the intervention limit, care should be taken to ensure that a thorough investigation is made that production stops on this production line, and that all radiators produced before and after this sample was taken are not put to any other use until the problem has been completely clarified. Further samples should be taken and tested if necessary on these radiators.

re 2.5 Coating

To ensure a uniform level of quality in the coating a cross-cut test should be made every day in accordance with EN ISO 2409 on the surface of a cool radiator outside the welding area and without any further conditioning.

The cross-cut reading of Gt 1 must not be exceeded as a maximum.

re 3.2 Internal monitoring

To ensure a uniform level of quality, the following specification should be met with regard to EN ISO 9001 for quality monitoring.

re EN ISO 9001 sub-section 5.6 Management evaluation

The user of the quality mark must carry out a review and revision of the quality system at least once a year.

re EN ISO 9001 sub-section 7.6 Management of monitoring and instrumentation equipment

Quality and Test Specifications

All items of measuring and testing equipment must be subjected to recurrent tests at the following intervals in order to ensure that all readings are accurate and that the equipment is not subject to any decline in accuracy.

Manometers	Every 3 months
Micrometers	Every 6 months
All other measuring, testing, and monitoring instruments	Every year
Testing normal (e.g.: final dimensions)	Every 5 years

re EN ISO 9001 sub-section on the verification of bought-in products

In the case of bought-in parts that have to withstand pressure, or that are relevant to the function and safety of the radiator, random samples have to be taken of incoming goods at the frequency shown below as a minimum:

Number of samples per consignment (Stage 0)

Up to	5,000 units	8 units,
Up to	20,000 units	16 units,
Over	20,000 units	20 units.

Or corresponding time-dependent determination of the number of random samples which at least meets these requirements.

Procedure for defects (acceptance / rejection)

If defects are discovered in the samples (acceptance = zero defects, rejection = one defect), a further test has to be carried out. If this also reveals defects, the entire consignment has to be sent back to the supplier or other suitable measures have to be taken to ensure that no defective bought-in parts find their way into production.

If consignments are no longer defective, the quality control checks on incoming goods can be reduced in stages:

Stage 1: When three consignments have arrived and revealed no defects the test can return to Stage 0 with half the number of units or, at the manufacturer's choice, only every second consignment needs to be checked.

Stage 2: When three more consignments have been delivered with no cause for complaint, the test level can be reduced to Stage 0 with one fourth of the number of units or, at the manufacturer's choice, only every fourth consignment needs to be checked.

If any consignment within the three Stages is defective, after that inspection must start again at Stage 0.

These checks on incoming goods can be omitted if there is some other way of verifying that the quality requirements for the bought-in parts are being met by a quality assurance system at the supplier's end that meets the stated minimum requirements.

re EN ISO 9001 sub-section on monitoring and measuring the product

The following requirements have to be made on the control specifications for production quality control checks:

Base material:

Sheet thickness	2 per coil, min. 2 per shift
Sheet widths	2 per coil, min. 2 per shift
Dimensions and curvature of semi-finished and finished goods:	2 per radiator type (or design), min. 2 per shift.

If defects are discovered by production control checks a further test has to be carried out. If this likewise reveals defects, suitable steps have to be taken to ensure that later products are not affected by any further defects.

Appendix A 2: Quality requirements for tubular steel sectional radiators

Section 2.3 Dimensions and limits

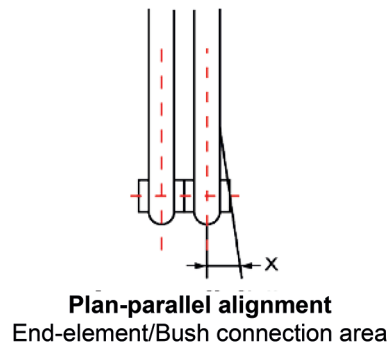
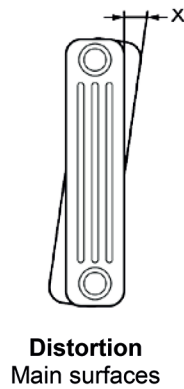
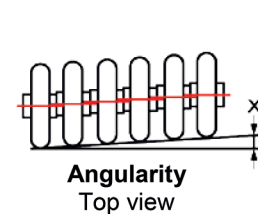
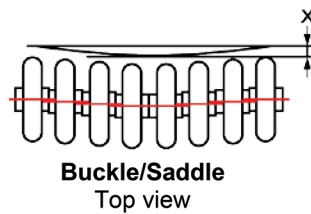
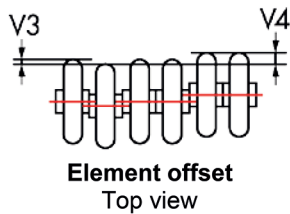
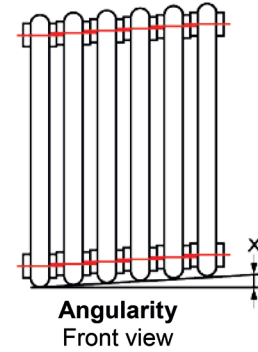
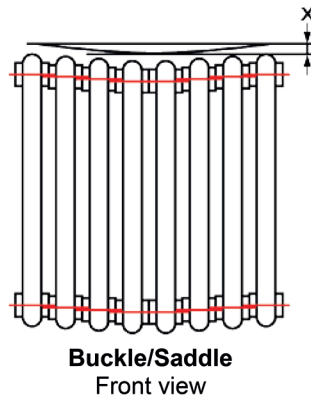
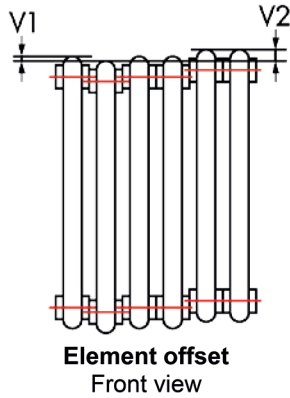

Property	Designation	Permissible deviation	Comments	
Element offset	Front view	V1	1.5 mm	From element to element Over entire block length
		V2	2.5 mm	
	Top view	V3	1.5 mm	
		V4	2.5 mm	
Buckle / saddle	X	4 mm/1000 mm ML	ML = measurement length	
Curvature	X	4 mm/1000 mm ML	ML = measurement length	
Angularity			ML = measurement length	
Front view	X	5 mm/1000 mm ML	ML = measurement length	
Top view	X	5 mm/1000 mm ML		
Rotation	X	1 mm/100(BH) -1000(BL)	¹	
Plan-parallel alignment	X	1 mm/100 mm ML	ML = measurement length	

¹ (BH) = construction height; (BL) = construction length

The values in EN 442-2, sub-section 4.3.3, table 3 must at least be complied with for all other dimensions, e.g. total construction height.

Quality and Test Specifications

DIN 2394 applies to the tolerances of tubes.

Complete radiators with a construction length of ≥ 1000 mm should be used for the dimensional test. They must stand or lie on a level surface.

re 2.4.3 Working pressure and pressure tests

The permissible working pressure of a tubular steel sectional radiator is at least 10 bar. In case of intermediate values for the pressure levels indicated, the requirements of the respective higher operating pressure are to be observed.

In addition to the test of pressure resistance under EN 442-1 sub-section 5.6, the manufacturer also has to carry out burst tests. The guideline figures for these tests and their related warning and intervention limits for each level of working pressure are shown in the following table.

Complete radiators with a construction length of at least 500 mm are to be used for the burst test.

Working pressure	10	16
Testing pressure	13	20.8
Guideline figure	20	32
Warning limit	19	30
Intervention limit	17	28

All figures show pressure over atmospheric pressure in bar

If the guideline figure is exceeded by 15% the burst test can be terminated.

The number of burst tests required is divided into Stages:

- Stage 1 1 test after 12 sections on each production line,
1 test after 500 sections on each production line,
- Stage 2 1 test on each working day and production line,
- Stage 3 1 test at intervals of no more than 5 working days on each production line.

Procedure for application

Stage 1 is to use when:

- new production lines are being started up,
- major changes have been made in production lines,
- new welding parameters are being calculated,
- production is being changed over to a higher pressure level,
- when readings fall short of the intervention limit.

This does not include:

- changes in construction height or length,
- model changes,
- insignificant changes in welding equipment,

If the readings do not fall short of the guideline figure after Stage 1, tests can be carried out in accordance with Stage 2.

If the readings do not fall short of the guideline figure after 10 consecutive tests in Stage 2, Stage 3 can be applied.

If the readings in any test fall short of the guideline figure but not of the warning limit, that Stage should be retained; only when once again 10 consecutive tests have been carried out without falling short of the guideline figure can tests be carried out at the next higher Stage.

If the readings in any test fall short of the warning limit, tests must then immediately be conducted according to the next lower Stage. When 10 consecutive tests have been conducted in which the readings did not fall short of the guideline figure, the subsequent tests can be carried out according to the next higher Stage.

If the readings fall short of the intervention limit, tests will be carried out according to the necessary measures under Stage 1 with the subsequent test procedure.

Action to be taken if readings fall short of the guideline figure

Corrective action is necessary if the readings fall short of the guideline figure and the warning limit. They are to be laid down and documented in the Procedural Instructions under the quality assurance system.

If the readings fall short of the intervention limit, care should be taken to ensure that a thorough investigation is made that production stops on this production line, and that all radiators produced before and after this sample was taken are not put to any other use until the problem has been completely clarified. Further samples should be taken and tested if necessary on these radiators.

The burst test can be omitted if there is any other way of ensuring that the quality requirements for pressure resistance are being met for the whole radiator, and particularly at the joints (weld joints, etc.) by a quality assurance system that meets the above minimum requirements. The auditor has to check the effectiveness of the system.

re 2.5 Coating

To ensure a uniform level of quality in the coating a cross-cut test should be made every day in accordance with DIN EN ISO 2409 on the surface of a radiator outside the welding spots. Following the cooling of the radiator to ambient temperature further conditioning is not necessary.

The cross-cut reading of Gt 1 must not be exceeded as a maximum.

re 3.2 Internal monitoring

To ensure a uniform level of quality, the following specification should be met with regard to EN ISO 9001 for quality monitoring.

re EN ISO 9001 sub-section 5.6 Management evaluation

The user of the quality mark must carry out a review and revision of the quality system at least once a year.

re EN ISO 9001 sub-section 7.6 Management of monitoring and instrumentation equipment

All items of measuring and testing equipment must be subjected to recurrent testings at the following intervals in order to ensure that all readings are accurate and that the equipment is not subject to any decline in accuracy.

Manometers (for radiator tests)	Every 3 months
Micrometers	Every 6 months
All other measuring, testing, and monitoring instruments	Every year
Testing normal (e.g.: final dimensions)	Every 5 years

re EN ISO 9001 sub-section on the verification of bought-in products

In the case of bought-in parts that have to withstand pressure, or that are relevant to the function and safety of the radiator, random samples have to be taken of incoming goods at the frequency shown below as a minimum:

Number of samples per consignment (Stage 0)

Up to	5,000 units	8 units,
Up to	20,000 units	16 units,
Over	20,000 units	20 units.

Or corresponding time-dependent determination of the number of random samples which at least meets these requirements.

Procedure for defects (acceptance / rejection)

If defects are discovered in the samples (acceptance = zero defects, rejection = one defect), a further test has to be carried out. If this also reveals defects, the entire consignment has to be sent back to the supplier or other suitable measures have to be taken to ensure that no defective bought-in parts find their way into production.

If consignments are no longer defective, the checks on incoming goods can be reduced in stages:

Stage 1: When three consignments have arrived and revealed no defects the inspection can return to Stage 0 with half the number of units or, at the manufacturer's choice, only every second consignment needs to be checked.

Stage 2: When three more consignments have been delivered with no cause for complaint, the test level can be reduced to Stage 0 with one fourth of the number of units or, at the manufacturer's choice, only every fourth consignment needs to be checked.

If any consignment within the three Stages is defective, after that tests must start again at Stage 0.

These checks on incoming goods can be omitted if there is some other way of verifying that the quality requirements for the bought-in parts are being met by a quality assurance system at the supplier's end that meets the stated minimum requirements.

re EN ISO 9001 sub-section on monitoring and measuring the product

The following requirements have to be made on the control specifications for production quality checks unless these have already been covered by the check on incoming goods:

Base material:

Sheet thickness	≥ 2 per coil,
Dimensions of semi-finished and finished goods:	per radiator type (or design), ≥ 2 per shift.

If defects are discovered by production quality checks a further test has to be carried out. If this likewise reveals defects, suitable steps have to be taken to ensure that later products are not affected by any further defects.

Appendix A 3: Quality requirements for heating walls and convectors

re 2.3 Dimensions and limits

Horizontal design

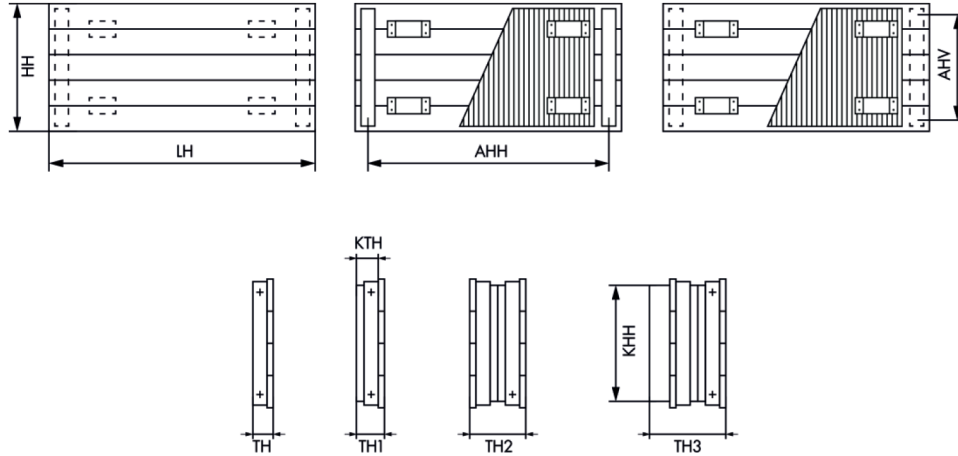

Property	Nominal dimension range	Designation type H	Permissible deviation	Comments
Total construction height	≤ 600 mm	HH	+ 4 / - 2 mm	
	> 600 mm	HH	+ 1% / - 0.5%	
Total construction depth		TH	± 2 mm	All multi-layer
		TH1	± 2 mm	
		TH2	+ 4 / - 2 mm	
		TH3	+ 4 / - 2 mm	
Total construction length	≤ 1000 mm	LH	± 4 mm	
	> 1000 mm ≤ 3000 mm	LH	± 5 mm	
	> 3000 mm	LH	± 0.25%	
Convector panel height		KHH	+ 3 / - 1 mm	
Convector panel depth		KTH	± 1 mm	
Bush separation	≤ 300 mm	AHH / AHV	± 2 mm	
	> 300 mm ≤ 1000 mm	AHH / AHV	± 4 mm	
	> 1000 mm ≤ 3000 mm	AHH / AHV	± 5 mm	
	> 3000 mm	AHH / AHV	± 0.25%	

Vertical design

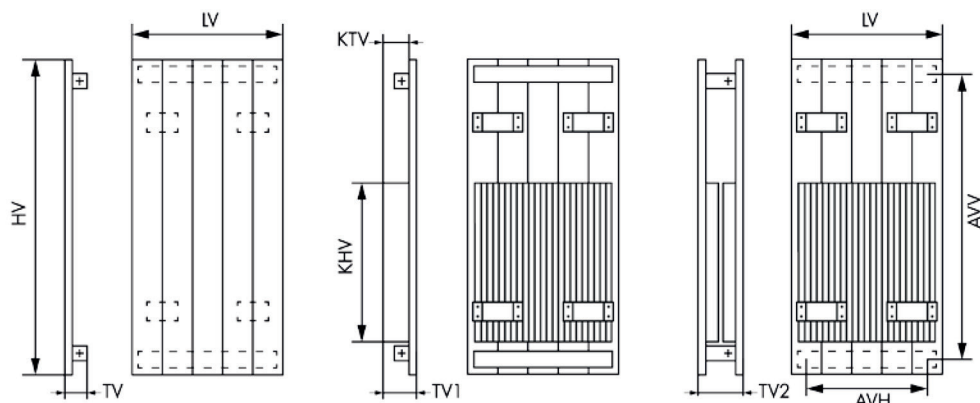

Property	Nominal dimension range	Designation type V	Permissible deviation	Comments
Total construction height	≤ 1000 mm	HV	± 4 mm	
	> 1000 mm	HV	± 5 mm	
	≤ 3000 mm	HV	± 0.25%	
	> 3000 mm	HV	± 0.25%	
Total construction depth		TV	± 2 mm	
		TV1	± 2 mm	
		TV2	+ 4 / - 2 mm	
Total construction length	≤ 600 mm	LV	± 4 mm	
	> 600 mm	LV	+ 1% / - 0.5%	
Convector panel height		KHV	+ 3 / - 1 mm	
Convector panel depth		KTV	± 1 mm	
Bush separation	≤ 300 mm	AVV / AVH	± 2 mm	
	> 300 mm	AVV / AVH	± 4 mm	
	≤ 1000 mm	AVV / AVH	± 4 mm	
	> 1000 mm	AVV / AVH	± 5 mm	
	≤ 3000 mm	AVV / AVH	± 5 mm	
	> 3000 mm	AVV / AVH	± 0.25%	

re 2.4.3 Working pressure and pressure tests

The permissible working pressure of heating walls and convectors made of flat pipes is at least 4 bar. In case of intermediate values for the pressure levels indicated, the requirements of the respective higher operating pressure are to be observed.

In addition to the test of pressure resistance under EN 442-1 sub-section 5.6, the manufacturer also has to carry out burst tests. The guideline figures for these tests and their related warning and interventions limits for each level of working pressure are shown in the following table.

Complete radiators with a construction length of at least 500 mm are to be used for the burst test.

Working pressure	4	5	6	8	10
Testing pressure	5.2	6.5	7.8	10.4	13
Guideline figure	8	10	12	16	20
Warning limit	7	9	11	15	19
Intervention limit	6	8	10	14	17

All figures show pressure over atmospheric pressure in bar

If the guideline figure is exceeded by 15% the burst test can be terminated.

The number of burst tests required is divided into Stages:

Stage 1 1 test after 10 radiator units on each production line,

Stage 2 1 test on each working day and production line,

Stage 3 1 test at intervals of no more than 5 working days on each production line.

Procedure for application

Stage 1 is to use when:

- new production lines are being started up,
- major changes have been made in production lines,
- new welding parameters are being calculated,
- when readings fall short of the intervention limit.

This does not include:

- changes in construction height or length,
- model changes,
- insignificant changes in welding equipment.

If the readings do not fall short of the guideline figure after Stage 1, tests can be carried out in accordance with Stage 2. If the readings do not fall short of the guideline figure after 10 consecutive tests in Stage 2, Stage 3 can be applied.

If the readings in any test fall short of the guideline figure but not of the warning limit, that Stage should be retained; only when once again 10 consecutive tests have been carried out without falling short of the guideline figure can tests be carried out at the next higher Stage.

If the readings in any test fall short of the warning limit, tests must then immediately be conducted according to the next lower Stage. When 10 consecutive tests have been conducted in which the readings did not fall short of the guideline figure, the subsequent tests can be carried out according to the next higher Stage.

If the readings fall short of the intervention limit, tests will be carried out according to the necessary measures under Stage 1 with the subsequent test procedure.

Action to be taken if readings fall short of the guideline figure

Corrective action is necessary if the readings fall short of the guideline figure and the warning limit. They are to be laid down and documented in the Procedural Instructions under the quality assurance system.

If the readings fall short of the intervention limit, care should be taken to ensure that a thorough investigation is made that production stops on this production line, and that all radiators produced before and after this sample was taken are not put to any other use until the problem has been completely clarified. Further random samples should be taken and tested if necessary on these radiators.

The burst test can be omitted if there is any other way of ensuring that the quality requirements for pressure resistance are being met for the whole radiator, and particu-

Quality and Test Specifications

larly at the joints (weld joints, etc.) by a quality assurance system that meets the above minimum requirements. The auditor has to check the effectiveness of the system.

re 2.5 Coating

To ensure a uniform level of quality in the coating a cross-cut test should be made every day in accordance with DIN EN ISO 2409 on the surface of a radiator outside the welding spots. No further conditioning of this sample is necessary after the radiator has cooled down to room temperature.

The cross-cut reading of Gt 1 must not be exceeded as a maximum.

re 3.2 Inspection

To ensure a uniform level of quality, the following specification should be met with regard to EN ISO 9001 for quality monitoring.

re EN ISO 9001 sub-section 5.6 Management evaluation

The user of the quality mark must carry out a review and revision of the quality system at least once a year.

re EN ISO 9001 sub-section 7.6 Management of monitoring and instrumentation equipment

All items of measuring and testing equipment must be subjected to recurrent tests at the following intervals in order to ensure that all readings are accurate and that the equipment is not subject to any decline in accuracy.

Manometers (for radiator tests)	Every 3 months
Micrometers	Every 6 months
All other measuring, testing, and monitoring instruments	Every year
Testing normal (e.g.: final dimensions)	Every 5 years

re EN ISO 9001 sub-section on the verification of bought-in products

In the case of bought-in parts that have to withstand pressure, or that are relevant to the function and safety of the radiator, random samples have to be taken of incoming goods at the frequency shown below as a minimum

Number of samples per consignment (Stage 0)

Up to	5,000 units	8 units,
Up to	20,000 units	16 units,
Over	20,000 units	20 units.

Or corresponding time-dependent determination of the number of random samples which at least meets these requirements.

Procedure for defects (acceptance / rejection)

If defects are discovered in the samples (acceptance = zero defects, rejection = one defect), a further test has to be carried out. If this also reveals defects, the entire consignment has to be sent back to the supplier or other suitable measures have to be taken to ensure that no defective bought-in parts find their way into production.

If consignments are no longer defective, the quality control checks on incoming goods can be reduced in stages:

Stage 1: When three consignments have arrived and revealed no defects the test can return to Stage 0 with half the number of units or, at the manufacturer's choice, only every second consignment needs to be checked.

Stage 2: When three more consignments have been delivered with no cause for complaint, the test level can be reduced to Stage 0 with one fourth of the number of units or, at the manufacturer's choice, only every fourth consignment needs to be checked.

If any consignment within the three Stages is defective, after that inspection must start again at Stage 0.

These checks on incoming goods can be omitted if there is some other way of verifying that the quality requirements for the bought-in parts are being met by a quality assurance system at the supplier's end that meets the stated minimum requirements.

re EN ISO 9001 sub-section on monitoring and measuring the product

The following requirements have to be made on the control specifications for production quality checks unless these have already been covered by the check on incoming goods:

Base material:

Sheet thickness	2 per coil, min. 2 per shift
Sheet width	2 per coil, min. 2 per shift
Dimensions of semi-finished and finished goods:	per radiator type (or design), ≥ 2 per shift.

If defects are discovered by production quality checks a further test has to be carried out. If this likewise reveals defects, suitable steps have to be taken to ensure that later products are not affected by any further defects.

Appendix A 4: Quality requirements for bathroom and designer radiators

This covers all types of radiator that cannot be clearly allocated to any of Appendices A1 to A3.

re 2.3 Dimensions and limits

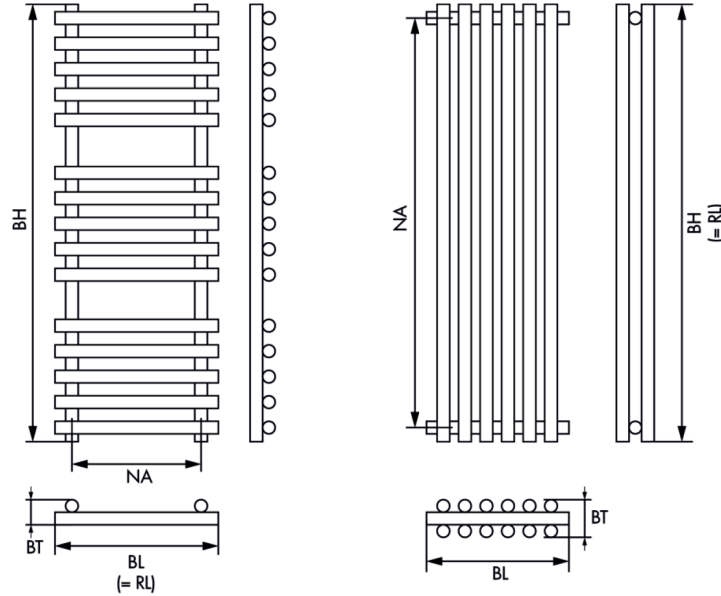

Property	Nominal dimension range	Designation type V	Permissible deviation	Comments
Total construction height	≤ 800 mm	BH	+ 4 / - 2 mm	
	>800 to ≤ 1200 mm	BH	+ 5 / - 2 mm	
	> 1200 mm	BH	+ 6 / - 2 mm	
Total construction depth	Single-row	BT	± 1.5 mm	See ²
	Double-row	BT	± 1.5 mm	
	Multiple-row	BT	± 1.5 mm	
Total construction length	≤ 600 mm	BL	± 3 mm	
	> 600 mm to ≤ 1000 mm	BL	± 4 mm	
	> 1000 mm	BL	± 0.5%	
Length of individual pipes	≤ 600 mm	RL	± 2 mm	
	> 600 mm	RL	± 3 mm	
Bush separation	≤ 600 mm	NA	± 2 mm	
	> 600 mm to ≤ 1000 mm	NA	± 4 mm	
	> 1000 mm to ≤ 3000 mm	NA	± 5 mm	
	> 3000 mm	NA	± 0.25%	

² Notwithstanding from EN 442-2, sub-section 4.3.3, table 3 for bathroom and designer radiators with different shapes (particularly those with curved elements), the tolerances shown in the manufacturer's drawings have to be observed for the total construction depth that is formed by these curved elements, but subject to a maximum of. ± 5 mm.

re 2.4.3 Working pressures and pressure tests

The permissible working pressure for bathroom and designer radiators made of tubular elements is at least 4 bar. In case of intermediate values for the pressure levels indicated, the requirements of the respective higher operating pressure are to be observed.

Supplementing the test for pressure resistance required by EN 442-1 sub-section 5.6, the manufacturer has to carry out burst tests. The guideline values for this, with the related warning and intervention limits corresponding to the relevant working pressure are shown in the following table.

Complete radiators with a construction length of at least 500 mm are to be used for the burst test.

Working pressure	4	6	8	10	16
Testing pressure	5.2	7.8	10.4	13	20.8
Guideline figure	8	12	16	20	32
Warning limit	7	11	15	19	30
Intervention limit	6	10	14	17	28

All figures show pressure over atmospheric pressure in bar

If the guideline figure is exceeded by 15% the burst test can be terminated.

Quality and Test Specifications

The number of burst tests required is divided into Stages:

- Stage 1 1 test after 10 radiator units on each production line,
- Stage 2 1 test on each working day and production line,
- Stage 3 1 test at intervals of no more than 5 working days on each production line.

Procedure for application

Stage 1 is to use when:

- new production lines are being started up,
- major changes have been made in production lines,
- new welding parameters are being calculated,
- readings fall short of the intervention limit.

This does not include:

- changes in construction height or length,
- model changes,
- insignificant changes in welding equipment,

If the readings do not fall short of the guideline figure after Stage 1, tests can be carried out in accordance with Stage 2.

If the readings do not fall short of the guideline figure after 10 consecutive tests in Stage 2, Stage 3 can be applied.

If the readings in any test fall short of the guideline figure but not of the warning limit, that Stage should be retained; only when once again 10 consecutive tests have been carried out without falling short of the guideline figure can tests be carried out at the next higher Stage.

If the readings in any test fall short of the warning limit, tests must then immediately be conducted according to the next lower Stage. When 10 consecutive tests have been conducted in which the readings did not fall short of the guideline figure, the subsequent tests can be carried out according to the next higher Stage.

If the readings fall short of the intervention limit, tests will be carried out according to the necessary measures under Stage 1 with the subsequent test procedure.

Action to be taken if readings fall short of the guideline figure

Corrective action is necessary if the readings fall short of the guideline figure and the warning limit. They are to be laid down and documented in the Procedural Instructions under the quality assurance system.

If the readings fall short of the intervention limit, care should be taken to ensure that a thorough investigation is made that production stops on this production line, and that all radiators produced before and after this sample was taken are not put to any other use until the problem has been completely clarified. Further random samples should be taken and tested if necessary on these radiators.

The burst test can be omitted if there is any other way of ensuring that the quality requirements for pressure resistance are being met for the whole radiator, and particularly at the joints (weld joints, etc.) by a quality assurance system that meets the above minimum requirements. The auditor has to check the effectiveness of the system.

re 2.5 Coating

To ensure a uniform level of quality in the coating a cross-cut test should be made every day in accordance with DIN EN ISO 2409 on the surface of a radiator outside the welding area. No further conditioning of this sample is necessary after the radiator has cooled down to room temperature.

The cross-cut reading of Gt 1 must not be exceeded as a maximum.

re 3.2 Internal monitoring

To ensure a uniform level of quality, the following specification should be met with regard to EN ISO 9001 for quality monitoring.

re EN ISO 9001 sub-section 5.6 Management evaluation

The user of the quality mark must carry out a review and revision of the quality system at least once a year.

re EN ISO 9001 sub-section 7.6 Management of monitoring and instrumentation equipment

All items of measuring and testing equipment must be subjected to recurrent testing at the following intervals in order to ensure that all readings are accurate and that the equipment is not subject to any decline in accuracy.

Manometers (for radiator tests)	Every 3 months
Micrometers	Every 6 months
All other measuring, testing, and monitoring instruments	Every year
Testing normal (e.g.: final dimensions)	Every 5 years

re EN ISO 9001 sub-section on the verification of bought-in products

In the case of bought-in parts that have to withstand pressure, or that are relevant to the function and safety of the radiator, random samples have to be taken of incoming goods at the frequency shown below as a minimum

Number of samples per consignment (Stage 0)

Up to	5,000 units	8 units,
Up to	20,000 units	16 units,
Over	20,000 units	20 units.

Or corresponding time-dependent determination of the number of random samples which at least meets these requirements.

Procedure for defects (acceptance / rejection)

If defects are discovered in the samples (acceptance = zero defects, rejection = one defect), a further test has to be carried out. If this also reveals defects, the entire consignment has to be sent back to the supplier or other suitable measures have to be taken to ensure that no defective bought-in parts find their way into production.

If consignments are no longer defective, the quality control checks on incoming goods can be reduced in stages:

Stage 1: When three consignments have arrived and revealed no defects the test can return to Stage 0 with half the number of units or, at the manufacturer's choice, only every second consignment needs to be checked.

Stage 2: When three more consignments have been delivered with no cause for complaint, the test level can be reduced to Stage 0 with one fourth of the number of units or, at the manufacturer's choice, only every fourth consignment needs to be checked

If any consignment within the three Stages is defective, after that inspection must start again at Stage 0.

These tests on incoming goods can be omitted if there is some other way of verifying that the quality requirements for the bought-in parts are being met by a quality assurance system at the supplier's end that meets the stated minimum requirements.

re EN ISO 9001 sub-section on monitoring and measuring the product

The following requirements have to be made on the control specifications for production quality checks unless these have already been covered by the check on incoming goods:

Dimensions of semi-finished and finished goods:	per radiator type (or design), ≥ 2 per shift.
---	--

If defects are discovered by production quality checks a further tests has to be carried out. If this likewise reveals defects, suitable steps have to be taken to ensure that later products are not affected by any further defects.

Appendix A 5: Quality requirements for steel element radiators

re 2.3 Dimensions and limits

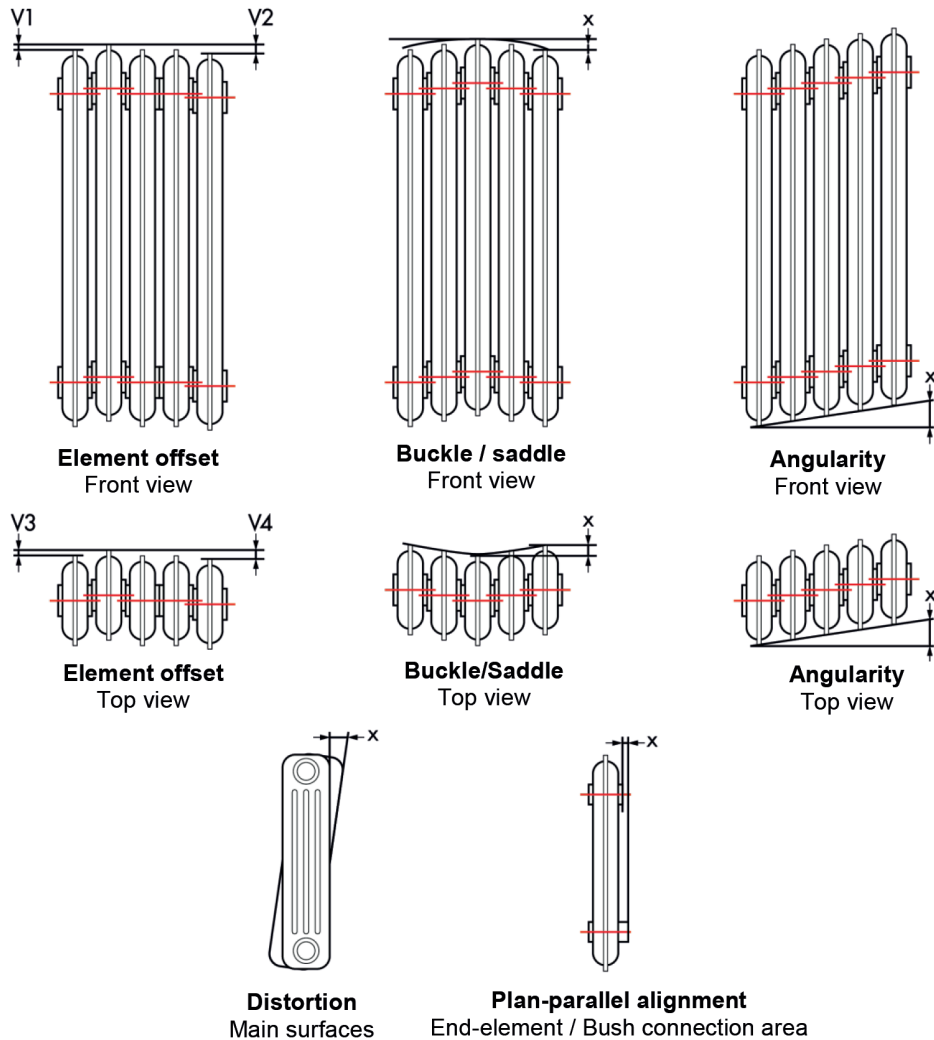

Property	Designation	Permissible deviation	Comments
Element offset			
Front view	V1	$\leq 1.5 \text{ mm}$	From element to element
	V2	$\leq 2.5 \text{ mm}$	Over entire block length
Top view	V3	$\leq 1.5 \text{ mm}$	From element to element
	V4	$\leq 2.5 \text{ mm}$	Over entire block length
Buckle / saddle	X	$\leq 4 \text{ mm}/1000 \text{ mm ML}$	ML = measurement length
Curvature	X	$\leq 4 \text{ mm}/1000 \text{ mm ML}$	ML = measurement length
Angularity			
Front view	X	$\leq 5 \text{ mm}/1000 \text{ mm ML}$	ML = measurement length
Top view	X	$\leq 5 \text{ mm}/1000 \text{ mm ML}$	ML = measurement length
Rotation	X	$\leq 1 \text{ mm}/100(\text{BH}) - 1000(\text{BL})$	*)
Plan-parallel alignment	X	$\leq 1 \text{ mm}/100 \text{ mm ML}$	ML = measurement length

*) (BH) = construction height; (BL) = construction length

The values in EN 442-2, sub-section 4.3.3, table 3 must at least be complied with for all other dimensions e.g. total construction height.

Complete radiators with a construction length of ³ 1000 mm should be used for the dimensional test. They must stand or lie on a level surface.

re 2.4.3 Working pressure and pressure tests

The permissible working pressure of a steel element radiator is at least 4 bar. In case of intermediate values for the pressure levels indicated, the requirements of the respective higher operating pressure are to be observed.

In addition to the test of pressure resistance under EN 442-1 sub-section 5.6, the manufacturer also has to carry out burst tests. The guideline figures for these tests and their related warning and interventions limits for each level of working pressure are shown in the following table.

Complete radiators with a construction length of at least 500 mm are to be used for the burst test.

Working pressure	4	6
Testing pressure	5.2	7.8
Guideline figure	8	12
Warning limit	7.6	11
Intervention limit	6.8	10

All figures show pressure over atmospheric pressure in bar

If the guideline figure is exceeded by 15% the burst test can be terminated.

The number of burst tests required is divided into Stages:

- Stage 1 1 test after 12 elements on each production line,
1 test after 500 elements on each production line,
- Stage 2 1 test on each working day and production line,
- Stage 3 1 test at intervals of no more than 5 working days on each production line.

Procedure for application

Stage 1 is to use when:

- new production lines are being started up,
- major changes have been made in production lines,
- new welding parameters are being calculated,
- production is being changed over to a higher pressure level,
- when readings fall short of the intervention limit.

This does not include:

- changes in construction height or length,
- model changes,
- insignificant changes in welding equipment,

If the readings do not fall short of the guideline figure after Stage 1, tests can be carried out in accordance with Stage 2.

If the readings do not fall short of the guideline figure after 10 consecutive tests in Stage 2, Stage 3 can be applied.

If the readings in any test fall short of the guideline figure but not of the warning limit, that Stage should be retained; only when once again 10 consecutive tests have been carried out without falling short of the guideline figure can tests be carried out at the next higher Stage.

If the readings in any test fall short of the warning limit, tests must then immediately be conducted according to the next lower Stage. When 10 consecutive tests have been conducted in which the readings did not fall short of the guideline figure, the subsequent tests can be carried out according to the next higher Stage.

If the readings fall short of the intervention limit, tests will be carried out according to the necessary measures under Stage 1 with the subsequent test procedure.

Action to be taken if readings fall short of the guideline figure

Corrective action is necessary if the readings fall short of the guideline figure and the warning limit. They are to be laid down and documented in the Procedural Instructions under the quality assurance system.

If the readings fall short of the intervention limit, care should be taken to ensure that a thorough investigation is made that production stops on this production line, and that all radiators produced before and after this sample was taken are not put to any other use until the problem has been completely clarified. Further random samples should be taken and tested if necessary on these radiators.

re 2.5 Coating

To ensure a uniform level of quality in the coating a cross-cut test should be made every day in accordance with DIN EN ISO 2409 on the surface of a radiator outside the welding spots. No further conditioning of this sample is necessary after the radiator has cooled down to room temperature.

The cross-cut reading of Gt 1 must not be exceeded as a maximum.

re 3.2 Internal monitoring

To ensure a uniform level of quality, the following specification should be met with regard to EN ISO 9001 for quality monitoring.

re EN ISO 9001 sub-section 5.6 Management evaluation

The user of the quality mark must carry out a review and revision of the quality system at least once a year.

re EN ISO 9001 sub-section 7.6 Management of monitoring and instrumentation equipment

All items of measuring and testing equipment must be subjected to recurrent testing at the following intervals in order to ensure that all readings are accurate and that the equipment is not subject to any decline in accuracy.

Manometers (for radiator tests)	Every 3 months
Micrometers	Every 6 months
All other measuring, testing, and monitoring instruments	Every year
Testing normal (e.g.: final dimensions)	Every 5 years

re EN ISO 9001 sub-section on the verification of bought-in products

Quality and Test Specifications

In the case of bought-in parts that have to withstand pressure, or that are relevant to the function and safety of the radiator, random samples have to be taken of incoming goods at the frequency shown below as a minimum Number of samples per consignment (Stage 0)

Up to	5,000 units	8 units,
Up to	20,000 units	16 units,
Over	20,000 units	20 units.

Or corresponding time-dependent determination of the number of random samples which at least meets these requirements.

Procedure for defects (acceptance / rejection)

If defects are discovered in the samples (acceptance = zero defects, rejection = one defect), a further test has to be carried out. If this also reveals defects, the entire consignment has to be sent back to the supplier or other suitable measures have to be taken to ensure that no defective bought-in parts find their way into production.

If consignments are no longer defective, the quality control checks on incoming goods can be reduced in stages:

Stage 1: When three consignments have arrived and revealed no defects the test can return to Stage 0 with half the number of units or, at the manufacturer's choice, only every second consignment needs to be checked.

Stage 2: When three more consignments have been delivered with no cause for complaint, the test level can be reduced to Stage 0 with one fourth of the number of units or, at the manufacturer's choice, only every fourth consignment needs to be checked.

If any consignment within the three Stages is defective, after that the tests must start again at Stage 0.

These tests on incoming goods can be omitted if there is some other way of verifying that the quality requirements for the bought-in parts are being met by a quality assurance system at the supplier's end that meets the stated minimum requirements.

re EN ISO 9001 sub-section on monitoring and measuring the product

The following requirements have to be made on the control specifications for production quality checks unless these have already been covered by the check on incoming goods:

Base material:

Sheet thickness	≥ 2 per coil
Dimensions of semi-finished and finished goods:	per radiator type (or design), ≥ 2 per shift.

If defects are discovered by production quality checks a further test has to be carried out. If this likewise reveals defects, suitable steps have to be taken to ensure that later products are not affected by any further defects.

Appendix A 6: Quality requirements for ribbed tube convectors

re 2.2 Materials

The ribs and tubes have to be made from corrosion-resistant materials, or materials that form their own protective layer, or else must be coated in accordance with sub-section 2.5. The same requirements apply to the housing, the shaft, and the cover if they are component parts of the product.

re 2.3 Dimensions and limits

Examples of ribbed tube convectors and their installation situations:

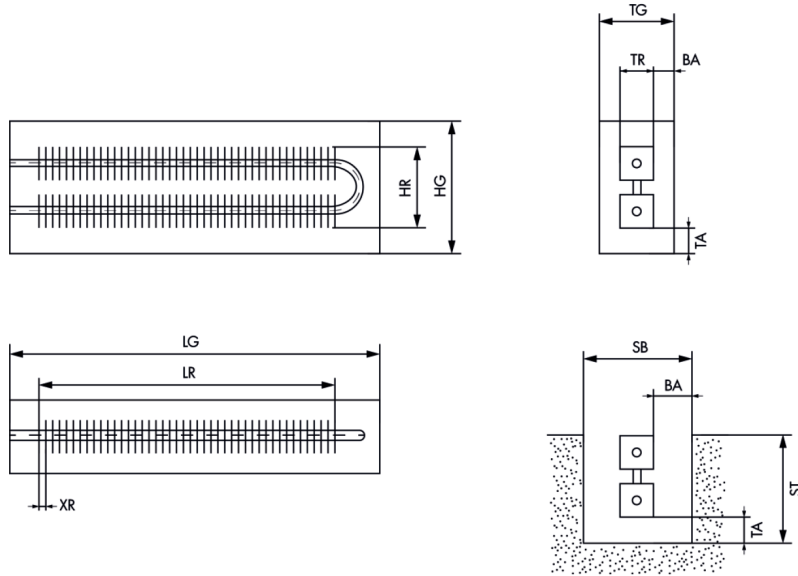

Examples of rib shapes and dimensions:

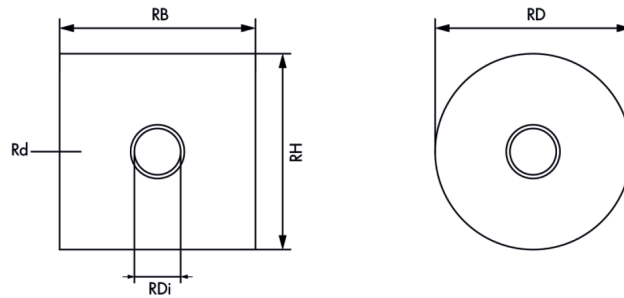

Property	Designation	Permissible deviations in mm	Comments
Housing dimensions	HG	± 2.0	As defined in EN 442-2
	TG		
	LG		
Register construction height	HR	± 0.5	Height of complete register
Register construction depth	TR	± 0.5	Depth of complete register
Ribbed length	LR	± 1.5	
Rib dimensions	RH	± 0.025	As defined in EN 442-2
	RB		
	RD		
Rib thickness	Rd	± 0.05	As defined in EN 442-2
Division of the register	XR	± 0.5	Measured at the rib foot
Number of ribs	ZR	± 1.0	As defined in EN 442-2
Internal diameter of tubes	RDl	± 0.10	As defined in EN 442-2. Only relevant to the manufacturer's statement of the heat output

Manufacturer's information

Property	Designation	Permissible deviations in mm	Comments
Distance from bottom edge of register to bottom edge of housing	TA	± 5	In the case of under-floor installation (with no housing) the distance from the bottom edge of the register to the floor is ± 10 mm
Distance from side edge of register to side edge of housing	BA	± 5	In the case of under-floor installation (with no housing) the distance from the side edge of the register to the wall is ± 10 mm
Shaft width	SB	± 2.0	Only for under-floor installation
Shaft depth	ST	± 2.0	Only for under-floor installation

re 2.4.2 Joining technique

All characteristics defined in the design as referring to joining technique, such as the connections between pipes and ribs, have to be defined in the production drawings and adhered to in production.

re 2.4.3 Working pressures and pressure tests

The permissible working pressure for ribbed tube convectors is at least 4 bar. In case of intermediate values for the pressure levels indicated, the requirements of the respective higher operating pressure are to be observed.

Supplementing the test for pressure resistance required by EN 442-1 sub-section 5.6, the manufacturer has to carry out burst tests. The guideline values for this, with the related warning and intervention limits corresponding to the relevant working pressure are shown in the following table.

Complete radiators with a construction length of at least 500 mm are to be used for the burst test.

Working pressure	4	6	8	10	16
Testing pressure	5.2	7.8	10.4	13	20.8
Guideline figure	8	12	16	20	32
Warning limit	7	11	15	19	30
Intervention limit	6	10	14	17	28

All figures show pressure over atmospheric pressure in bar

If the guideline figure is exceeded by 15% the burst test can be terminated.

The number of burst tests required is divided into Stages:

Stage 1 1 test after 10 tube registers on each production line,
1 test after 100 tube registers on each production line

Stage 2 1 test on each working day and production line,

Stage 3 1 test at intervals of no more than 5 working days on each production line.

Procedure for application

Stage 1 is to use when:

- new production lines are being started up,
- major changes have been made in production lines,
- new welding parameters are being calculated for water-carrying connections, e.g. welding or brazing
- production is being changed over to a higher pressure level,
- readings fall short of the intervention limit.

This does not include:

- changes in construction height or length,
- model changes,
- insignificant changes in processing equipment,

If the readings do not fall short of the guideline figure after Stage 1, tests can be carried out in accordance with Stage 2.

If the readings do not fall short of the guideline figure after 10 consecutive tests in Stage 2, Stage 3 can be applied.

If the readings in any test fall short of the guideline figure but not of the warning limit, that Stage should be retained; only when once again 10 consecutive tests have been carried out without falling short of the guideline figure can tests be carried out at the next higher Stage.

If the readings in any test fall short of the warning limit, tests must then immediately be conducted according to the next lower Stage. When 10 consecutive tests have been conducted in which the readings did not fall short of the guideline figure, the subsequent tests can be carried out according to the next higher Stage.

If the readings fall short of the intervention limit, tests will be carried out according to the necessary measures under Stage 1 with the subsequent test procedure.

Action to be taken if readings fall short of the guideline figure

Corrective action is necessary if the readings fall short of the guideline figure and the warning limit. They are to be laid down and documented in the Procedural Instructions under the quality assurance system.

If the readings fall short of the intervention limit, care should be taken to ensure that a thorough investigation is made that production stops on this production line, and that all radiators produced before and after this sample was taken are not put to any other use until the problem has been completely clarified. Further random samples should be taken and tested if necessary on these radiators.

The burst test can be omitted if there is any other way of ensuring that the quality requirements for pressure resistance are being met for the whole radiator, and particularly at the joints with sealing function (weld joints, etc.) by a quality assurance system that meets the above minimum requirements. The auditor has to check the effectiveness of the system.

re 2.5 Coating

To ensure a uniform level of quality in the coating a cross-cut test should be made every day in accordance with DIN EN ISO 2409 on the surface of a radiator outside the welding spots. No further conditioning of this sample is necessary after the radiator has cooled down to room temperature.

The cross-cut reading of Gt 1 must not be exceeded as a maximum.

re 3.2 Internal monitoring

To ensure a uniform level of quality, the following specification should be met with regard to EN ISO 9001 for quality monitoring.

re EN ISO 9001 sub-section 5.6 Management evaluation

The user of the quality mark must carry out a review and revision of the quality system at least once a year.

re EN ISO 9001 sub-section 7.6 Management of monitoring and instrumentation equipment

All items of measuring and testing equipment must be subjected to recurrent testing at the following intervals in order to ensure that all readings are accurate and that the equipment is not subject to any decline in accuracy.

Manometers (for radiator tests)	Every 3 months
Micrometers	Every 6 months
All other measuring, testing, and monitoring instruments	Every year
Testing normal (e.g.: final dimensions)	Every 5 years

re EN ISO 9001 sub-section on the verification of bought-in products

In the case of bought-in parts that have to withstand pressure, or that are relevant to the function and safety of the radiator, random samples have to be taken of incoming goods at the frequency shown below as a minimum

Number of samples per consignment (Stage 0)

Up to	5,000 units	8 units,
Up to	20,000 units	16 units,
Over	20,000 units	20 units.

Or corresponding time-dependent determination of the number of random samples which at least meets these requirements.

Procedure for defects (acceptance / rejection)

If defects are discovered in the samples (acceptance = zero defects, rejection = one defect), a further test has to be carried out. If this also reveals defects, the entire consignment has to be sent back to the supplier or other suitable measures have to be taken to ensure that no defective bought-in parts find their way into production.

If consignments are no longer defective, the quality control checks on incoming goods can be reduced in stages:

Stage 1: When three consignments have arrived and revealed no defects the test can return to Stage 0 with half the number of units or, at the manufacturer's choice, only every second consignment needs to be checked.

Stage 2: When three more consignments have been delivered with no cause for complaint, the test level can be reduced to Stage 0 with one fourth of the number of units or, at the manufacturer's choice, only every fourth consignment needs to be checked.

If any consignment within the three Stages is defective, after that the test must start again at Stage 0.

These tests on incoming goods can be omitted if there is some other way of verifying that the quality requirements for the bought-in parts are being met by a quality assurance system at the supplier's end that meets the stated minimum requirements.

re EN ISO 9001 sub-section on monitoring and measuring the product

The following requirements have to be made on the control specifications for production quality control checks unless these have already been covered by the check on incoming goods:

Base material:

Sheet thickness	2 per batch, min. 2 per shift
Sheet width	2 per batch, min. 2 per shift
Wall thicknesses	2 per batch, min. 2 per shift
Dimensions of semi-finished and finished goods:	2 per radiator type (or design), min. 2 per shift.

If defects are discovered by production quality checks a further test has to be carried out. If this likewise reveals defects, suitable steps have to be taken to ensure that later products are not affected by any further defects.

Appendix B: Selection of models for testing from model series and families

Appendix B 1: Model “triangle”: Selection of models for testing

Convector panel height in mm ↑	1050															
	980															
	910															
	840															
	770															
	700															
	630															
	560															
	490															
	420															
	350															
	280				x											
	210			o	o											
	140		o	o	o											
	70	x	o	o	x											
	70	140	210	280	350	420	490	560	630	700	770	840	910	980	1050	
o not to be tested x to be tested																

Construction height in mm →

Convector panel height in mm ↑	1050															
	980															
	910															
	840															
	770															
	700															
	630															
	560								x	o	x					
	490							o	o	o	o					
	420						o	o	o	o	o					
	350					x	o	o	x	o	x					
	280				o	o	o	o	o	o	o					
	210			o	o	o	o	o	o	o	o					
	140		o	o	o	o	o	o	o	o	o					
	70	x	o	o	o	x	o	o	x	o	x					
	70	140	210	280	350	420	490	560	630	700	770	840	910	980	1050	
o not to be tested x to be tested																

Construction height in mm →

Quality and Test Specifications

Convector panel height in mm ↑	1050															x
	980														o	o
	910													o	o	o
	840												o	o	o	o
	770											o	o	o	o	o
	700										x	o	o	o	o	x
	630									o	o	o	o	o	o	o
	560								o	o	o	o	o	o	o	o
	490							o	o	o	o	o	o	o	o	o
	420						o	o	o	o	o	o	o	o	o	o
	350					x	o	o	o	o	x	o	o	o	o	x
	280				o	o	o	o	o	o	o	o	o	o	o	o
	210			o	o	o	o	o	o	o	o	o	o	o	o	o
	140		o	o	o	o	o	o	o	o	o	o	o	o	o	o
	70	x	o	o	o	x	o	o	o	o	x	o	o	o	o	x
		70	140	210	280	350	420	490	560	630	700	770	840	910	980	1050
o not to be tested x to be tested																
Construction height in mm →																

Appendix B 2.1: Model family in the broader sense: Typical example

Panel radiator

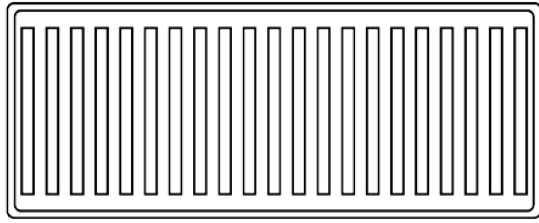

Heating wall

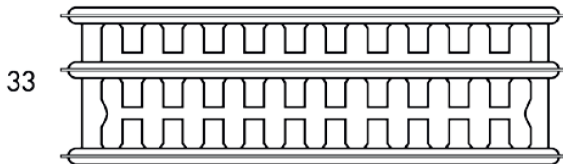
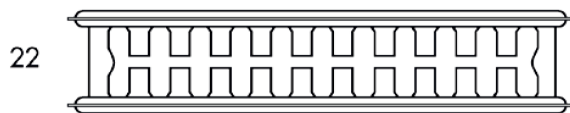
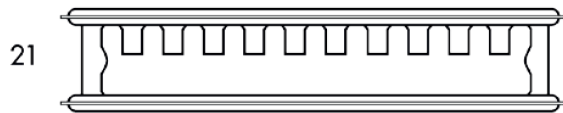
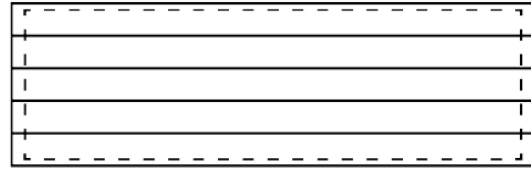

Appendix B 2.2: Model family in the broader sense: Selection of models for testing

Panel radiator:

Construction depth (secondary characteristic dimension)	44	x	o	o	o	x	o	o	x
	33	x	o	o	o	x	o	o	x
	22	x	o	o	o	x	o	o	x
	11	x	o	o	o	x	o	o	x
		300	400	500	600	700	800	900	1000
o not to be tested x to be tested									
Construction height (primary characteristic dimension)									

Heating wall:

Construction depth (secondary characteristic dimension)	55	x	o	o	o	x	o	o	x
	44	x	o	o	o	x	o	o	x
	33	x	o	o	o	x	o	o	x
	22	x	o	o	o	x	o	o	x
	11	x	o	o	o	x	o	o	x
		350	420	490	560	630	700	770	840
o not to be tested x to be tested									
Construction height (primary characteristic dimension)									

Appendix B 3.1: Model family in the narrower sense: Typical example

Panel radiator

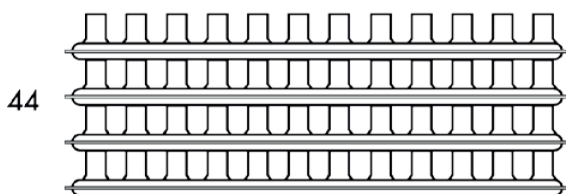
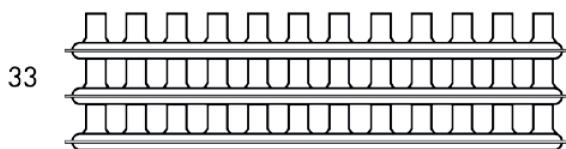
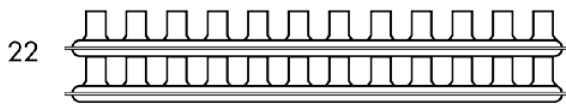
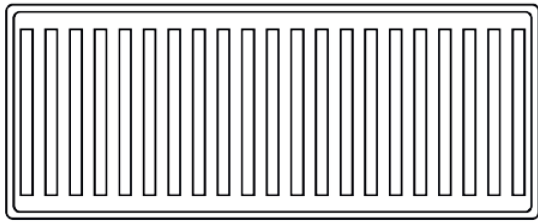

Heating wall

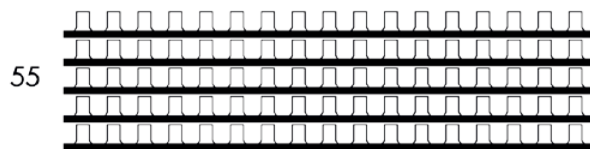
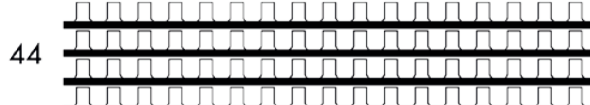

Appendix B 3.2: Model family in the narrower sense: Selection of models for testing

Panel radiator:

Construction depth (secondary characteristic dimension)	44	x	o	o	o	x	o	o	x
	33	x	o	o	o	x	o	o	x
	22	o	o	o	o	o	o	o	o
	11	x	o	o	o	x	o	o	x
		300	400	500	600	700	800	900	1000
o not to be tested x to be tested									
Construction height (primary characteristic dimension)									

Heating wall:

Construction depth (secondary characteristic dimension)	55	x	o	o	o	x	o	o	x
	44	o	o	o	o	o	o	o	o
	33	x	o	o	o	x	o	o	x
	22	o	o	o	o	o	o	o	o
	11	x	o	o	o	x	o	o	x
		350	420	490	560	630	700	770	840
o not to be tested x to be tested									
Construction height (primary characteristic dimension)									

Appendix C: Confirmation that the appendix to the obligation note is up to date

It is hereby confirmed that the Appendix to the Obligation Note of the firm of

Example GmbH & Co, Cologne	
XY manufacturing plant	
with the headings	1 to 6 (page 1 dated 00.xx.1995) 7 to 18 (page 2 dated 00.1996)

Is still fully valid.

Date:	
Name:	
Signature:	

Executive Regulations for the awarding and holding of the quality mark for steel radiators

1 Quality basis

The basis for the quality mark consists of the quality and testing regulations for steel radiators. They are constantly being augmented and further developed in order to adapt them to technical progress.

2 Award

2.1 The Gütegemeinschaft Heizkörper aus Stahl e. V. (the "Steel radiators quality association", referred to here for short as the "Association") awards the right to bear its "Steel radiator" quality mark to manufacturers of steel radiators on application. In addition to this the quality mark can be awarded to any applicants in respect of radiators that they do not manufacture themselves if they hold at least one RAL certificate from the Association for radiators that they do manufacture themselves. The production locations for the radiators that manufacturers do not produce themselves are treated as an additional production location.

2.2 The application has to be made in writing to the Association's business office in Frankfurter Straße 720-726, 51145 Cologne and has to be accompanied by the Obligation Note, signed by an authorised signatory (Sample 1), and the documentation listed therein.

2.3 When the Quality Committee has inspected the application documentation for completeness the initial inspection is carried out on the basis of the application and in accordance with sub-section 3.1 of these Executive Regulations.

An independent expert or a testing organisation recognised by the Quality Committee (see Quality and Inspection Regulations, Section 3) inspects the applicant's products in accordance with the Quality and Inspection Regulations. They can inspect the applicant's operational location and request and scrutinise the documentation mentioned in the Quality and Inspection Regulations.

If the inspection yields positive results the Quality Committee issues a certificate to the applicant that confirms the conformity of his products to the Quality and Inspection Regulations and gives him the right to use this certificate in accordance with the Association's regulations.

The certificate contains the manufacturer's identification number and a table showing all the certified products with their registration numbers. The standard heat output figures as defined in EN 442 are deposited with the Association under these registration numbers.

The person entrusted with carrying out the initial test has to show proof of his or her authorisation before starting work.

The applicant bears the costs of the tests.

2.4 If the certificate issued by the Quality Committee confirms that the applicant's products conform to the Quality and Inspection Regulations, the Association will award him the quality mark. The award is documented (Sample 2).

The application submitted to the Quality Committee loses the validity of the attached Obligation Note one year at the latest after it was issued.

2.5 With the award of the RAL quality mark, the manufacturer agrees that the following information shall be provided on the website www.wspcert-ral.de:

- Delta T 50K
- Delta T 30K
- Radiator exponent n
- Maximum operation pressure
- Characteristic nominal dimensions (height, depth, length, type/model)
- Manufacturer's product name
- Registration number
- Name of manufacturer
- Manufacturer's plant
- Date of Award Certificate

3 Use

3.1 Users of the quality mark are allowed to use it only for those products that meet the Quality and Inspection Regulations.

The allocated registration number is only allowed to be used unambiguously for the model or model series for which certification has been issued.

3.2 The Association is solely entitled to arrange for labelling aides to be produced for the quality mark and made available to the user, and also to define in detail the way in which it is to be used.

3.3 The Executive Committee can issue special regulations on the use of the quality mark in advertising and in co-operative advertising in order to ensure fairness in competition and prevent any misuse of the mark. These regulations will not be allowed to affect the user's individual advertising, which are governed by the same principles of fair competition.

3.4 If the mark has been withdrawn with final legal effect the certificate of award and any labelling aides for the quality mark have to be returned; the user will have no right to claim any compensation. The same applies if the right to use the mark expires for any other reason.

4 Monitoring

4.1 The Quality Committee is entitled and under an obligation to monitor the use of the quality mark and adherence to the Quality and Inspection Regulations. The continuity of monitoring has to be substantiated by a monitoring contract with a neutral expert or testing organisation (see Quality and Inspection Regulations, Section 3).

Durchführungsbestimmungen

4.2 All users of the quality mark must themselves ensure adherence to the Quality and Inspection Regulations. They are under an obligation to maintain a quality assurance system that at least meets the requirements of EN ISO 9001. Organisations that were accustomed in the past to using the EN ISO 9002 Standard have to apply this Standard by excluding certain requirements defined in sub-section 1.2 of EN ISO 9001. They subject those of their products that bear the quality mark to monitoring tests by the independent expert who is authorised to make them, or the authorised testing organisation, to the extent and with the frequency that meets the requirements of the Quality and Test Regulations.

The users of the quality mark bear the costs for all the necessary monitoring inspections under these Executive Regulations.

4.3 Auditors can request or take samples at any time from the mark users' operating locations. They can also take samples from the distributive trade. If samples are requested they have to be provided without delay. Auditors can inspect mark users' operating locations at any time during working hours.

4.4 If any test yields a negative result, or if there are grounds for complaint against a product that bears the quality mark, the Quality Committee can require the test to be repeated. The mark user can likewise request the test to be repeated.

4.5 An audit report has to be issued on every test. The inspected firm and the Quality Committee each receive one copy of this report.

4.6 If complaints are raised against products that bear the quality mark and later prove to be unfounded, the complainant bears the cost of the inspection; if the complaint is found to be justified, the mark user in question bears the cost.

5 Penalties for violations

5.1 If the Quality Committee discovers defects in the quality assessment system it will initiate the following measures in accordance with the information stated:

5.1.1 Additional requirements in connection with internal monitoring

These can be required as part of the measures for eliminating defects under sub-section 3.3.6 of the Quality and Inspection Regulations.

5.1.2 Increases in external monitoring

Additional external monitoring inspections can be required if there is a special reason for them, e.g. serious irregularities in the quality level of the product or in the quality assurance system.

5.1.3 Warning with period of notice

Warnings can be issued against users of the quality mark who violate the provisions of Section 3 or 4 above.

If the user of the quality mark has been definitely shown to be in violation, the Quality Committee will set a period

of time in which he has to rectify the deviations. Generally speaking this period of time will not exceed three months.

The warning with period of notice can be combined under certain circumstances with increased external monitoring.

5.1.4 Suspension of the validity of the certificate of conformity – temporary withdrawal of the quality mark.

If the warning with period of notice in connection with deviations as described in sub-clause 5.1.3 does not produce the desired result, the Quality Committee can suspend the validity of the certificate it has issued. In serious cases it can suspend validity immediately and without prior warning. The same also applies if safety, health, or the environment is endangered.

This also applies if users of the quality mark repeatedly violate Section 3 or 4 or if they delay or impede the tests.

When the period of time has elapsed for which the conformity certification had been suspended, a monitoring test is carried out to establish whether the conditions required by the Quality and Inspection Regulations are being met.

If they are being met, the quality mark user has to be informed that his conformity certification is now valid again.

The Association's Executive Committee takes every suspension of the validity of the conformity certification as grounds for temporarily withdrawing the quality mark.

The quality mark approval can also be temporarily withdrawn for the period of time of an interruption to production for any similar reason if this has been agreed by the Association's Executive Committee and the user of the quality mark.

The Association's Executive Committee has to state the conditions under which the temporary withdrawal will be terminated.

5.1.5 Cancellation of conformity certification – duration of withdrawal of mark

The Quality Committee is only allowed to cancel a conformity certification if the preceding measures described in sub-sections 5.1.1 to 5.1.4 with regard to the established deviations prove ineffective, or with immediate effect in serious cases.

If the check test that is carried out after the expiry of the period of time for the suspension of the conformity certification under the provisions of sub-section 5.1.4 fails to substantiate that the required conditions are being met, the Quality Committee can cancel the conformity certification.

The Association's Executive Committee can take every cancellation of the conformity certification as grounds for permanently withdrawing the quality mark.

The Association's Executive Committee will withdraw the quality mark permanently if the user informs it that he no longer needs the quality mark.

In urgent cases the Chairman of the Association can temporarily withdraw the quality mark with immediate effect. This action requires confirmation by the Association's Executive Committee within 14 days.

5.2 The user of the quality mark will be informed of these measures by means of a registered letter from the Association. In the case of a temporary withdrawal the letter will also state the duration of the withdrawal.

5.3 In the case of a temporary or permanent withdrawal of the quality mark as described in sub-sections 5.1.4 and 5.1.5, the Association's Executive Committee can require the user of the quality mark to remove the quality mark from the products concerned.

In the case of a temporary or permanent withdrawal of the quality mark the Association's Executive Committee will decide whether stocks of goods that bear the quality mark can be used up or whether the quality mark is to be removed from these products.

5.4 The user concerned is to be given a hearing in connection with any of these measures.

5.5 The penalty measures described in sub-sections 5.1 to 5.3 take effect as soon as they legally come into force.

6 Appeals

Quality mark users can raise an appeal against notices of penalty within 4 weeks of receiving them.

The appeal has to be submitted in writing by registered mail.

7 Re-awards

If the right to use the quality mark has been withdrawn, it cannot be re-awarded until a further period of at least three months has passed. The procedure will follow that described in Section 2. The Association's Executive Committee can impose additional conditions.

8 Changes

These Executive Regulations for the awarding and use of the quality mark and the appendices (Obligation Note and Certificate of Award) are accepted by RAL. No changes, including improvements to the wording, have any validity unless RAL has given its prior written consent. They take effect an appropriate length of time after the RAL Management Board has informed of them.

OBLIGATION NOTE

1. The undersigned person / company hereby applies to the *Gütegemeinschaft Heizkörper aus Stahl e.V.*:
O to be accepted as a member
O to be awarded the right to bear the quality mark for the steel radiators listed in the following table.
The table contains _____ pages.

2. The undersigned person / company hereby confirms that he/she/it has taken due note of the following:
 - the Statutes of the *Gütegemeinschaft Heizkörper aus Stahl e.V.*
 - the Statutes applicable to the quality mark
 - the Quality and Inspection Regulations for steel radiators
 - the Executive Regulations

and hereby accepts them without reservation as having binding effect.

Place and date

Stamp and signature

Each page of this Appendix to the Obligation Note must be signed by a legally authorised signatory and the name of the signatory must also be shown in block letters.

The copy of the test reports and all other documentation necessary for substantiating conformity to the Standards as required by sub-section 2.1.3.1 of the Quality and In-spection Regulations must be attached for all the radiator models listed in the table.

Appendix to the obligation note

List of registrations

Company
Manufacturing plant

GZ- Reg. no.	Process Date	Description	Registration list drawn up on:

It is hereby confirmed that the above registration lists are valid.

_____ Date

_____ Signature

_____ Name in block letters

Award Certificate

The Gütegemeinschaft Heizkörper aus Stahl e. V.
(Quality Association for Steel Radiators, reg. assoc.), on the basis of the certification
available to the latter's quality commission hereby awards

(the company)

Recognised by the RAL Deutsches Institut für Gütesicherung und Kennzeichnung e.V.
(RAL German Institute for Quality Assurance and Labelling, reg.
assoc.) and protected by registration with the German Patent Office as a
collective brand.

the Steel Radiators Quality Mark



The entitlement to bear the quality mark is applicable to all the models/series of
models in the respective current "directory of quality tested steel radiators"

Cologne, _____

Gütegemeinschaft Heizkörper aus Stahl e.V.

The President

Chairman of the Quality Committee



HISTORY

The Reichsausschuss für Lieferbedingungen (RAL) – Committee of the German Reich for Terms and Conditions of Sale – was founded in 1925 as a combined initiative of the German private sector and the German government of that time. The joint aim was the standardization and clear definition of precise technical terms of delivery. For this purpose, fixed quality standards and their control were needed – the system of quality assurance was born. Its implementation required the creation of an independent and neutral institution as a self-governing body of all parties active in the market. That was the moment of birth for RAL and ever since that time it has been the competent authority for the creation of quality labels.

RAL TODAY

RAL acts as an independent service provider in its fields of activity. It is recognized as a non-profit organization and organized in the legal form of a registered association. Its organs are Executive Committee, Board of Trustees, General Assembly of Members and the management.

RAL's independent and neutral position finds expression in the fact that the principles of its activities are established by the Board of Trustees which is composed of representatives from the leading organizations representing industry, consumers, agriculture, the federal ministries and other federal bodies. They have a permanent seat and vote on that body. In addition to them, the General Assembly of Members elects four quality assurance associations on the Board of Trustees as representatives of the RAL members.

RAL'S AREAS OF COMPETENCE

- RAL creates Quality Marks
- RAL is responsible for registrations, agreements and protected geographical origin marks

RAL DEUTSCHES INSTITUT FÜR GÜTESICHERUNG UND KENNZEICHNUNG E. V.
(RAL GERMAN INSTITUTE FOR QUALITY ASSURANCE AND CERTIFICATION)

Fränkische Straße 7 · 53229 Bonn Germany

Phone: +49 (0) 228 - 6 88 95-0

E-mail: RAL-Institut@RAL.de · Internet: www.RAL.de

